

**Model: DTV-07C**

**586 Series**

**Compact Line PC  
User's Manual**

**M/B Ver.4.0  
April.15/1999**

## CHAPTER 1 INTRODUCTIONS & KEY FEATURES

### 1.1 Introductions:

***Congratulation on the purchase of your DTV-07C !***

You are now the owner of a state-of-the-art DTV-07C - the one that offers features; speed; and performance, and the one that is unrivaled and unattended by other conventional Pentium-586-based PC.

### 1.2 Key Features:

**Model number:**

**DTV-07C**

**\*\*\* Options:**

**• DATA-POS → DTV-074S → 4S: 4 serial ports •**  
**• DATA-MEDIA → DTV-072S → 2S: 2 serial ports**  
**and with optional Internal CD ROM •**

CPU: Supports full series of Intel Pentium™ CPU, Cyrix/IBM, AMD  
*CPU CLOCK -* Intel Pentium™ 75Mhz up to 200Mhz. , Cyrix (IBM)  
6x86 ..166+, AMD K5.....  
*CPU VOLTAGE -* 5V, onboard voltage regulator: 2.5/ 3.3/ 3.45/ 3.56 V  
MAIN MEMORY: 72 Pin SIMM x 2pcs (Fast Page mode or EDO mode)  
BIOS *combines video:* Flash ROM - combines system BIOS with VIDEO BIOS in  
a single Flash ROM , system BIOS complying with PLUG and PLAY  
CACHE MEMORY: 256KB P.B.SRAM onboard, optional 0KB or 512KB  
EXPANSION SLOTS: Support Free **3-Slots Bus Card** consisting of :  
*ISA bus \* 2, PCI / ISA bus \* 1,*  
\*\*\* SERIAL PORT:  
**(4S: 4 Serial)** Four Serial ports, *freely selectable IRQ & base address range. 2 ports x RS232, 1 port x RS232/422/485, 1 port x RS232/422*  
**(2S: 2 Serial)** Two Serial ports, *freely selectable IRQ & base address range. 2 ports x RS232*  
PARALLEL PORT: One Parallel port (SPP/ EPP/ ECP)  
FDD: 1.44MB/ 3.5" FDD x 1  
ENHANCE PCI IDE: For AT bus IDE  
PCI XGA / SVGA/ VGA PORT  
(CRT, LCD):  
- 32bit Cirrus Logic 7548 chip default 1MB, up to 2MB  
- Display output to connect either MONITOR or COLOR LCD both can display simultaneously.  
- Connectors: CRT 15pin DSub and LCD 44pin DSub.  
- Integrated programmable frequency synthesizer, 24bit true-color, RAMDAC, 64\*64 pixel size hardware pop-up icons.  
- LCDs: 640\*480 (VGA), 800\*600 (SVGA) and 1024\*768 (XGA)  
\*\*\* WATCHDOG: *Driving triggered by software, Watchdog Timer defined by jumper setting from 1/4 to 256 seconds.*  
(Default spec for 4S)  
KEYBOARD PORT: Standard AT DIN keyboard.  
PS/2 MOUSE PORT: Yes  
FRONT PANEL: LED indicators: POWER, TURBO, HDD. Door Cover to protect floppy disk and power switch  
POWER SUPPLY: 80W Internal Power Supply (UL, CSA, VDE, EMI meets FCC \*B\*)

POWER SOURCE: AC 90V to 264V, 60HZ/50HZ  
CASE DIMENSION: 11"(W)x11"(D)x3"(H) (280x280x75mm)  
EXPORT PACKING: Each set packing: 13.5"x13.5"x6.75" (34x34x17cm)  
Each set NW/GW: 5kgs/ 6kgs.  
Two sets packing: 15.35"x15.35"x14.76" (39x39x37.5cm)  
SAFETY: **CE, FCC**  
S/W Compatibility: MS-DOS 4.01/5.0/6.2, OS2 V2.1, SCO XENIX: V2.3.2,  
SCO UNIX V3.2, NOVELL, WINDOWS 3.1/ 95/ NT  
OPERATION TEMPERATURE: 0 °C to 55 °C  
STORAGE TEMPERATURE: -25 °C to 70 °C

**Dimension:** Mainboard: 26.5cm(w) x15 cm(D); Screw Holes: 0.5cm.  
System: 28cm x 28cm x 7.5cm(11" x 11"x 3").

**Export Packing:** Each set packing 34cm x 34cm x 17cm (13.5" x 13.5" x 6.75").  
Two Sets packing 39cm x 39cm x 37.5cm(15.35" x 15.35" x 14.76").

### **OPTIONS:**

1. **COMBO CARD:** *Optional, built-in RAM DISK/ Cash drawer port \* 2 for +5V or +12V.*
2. **INTERNAL CD ROM KIT:** *Optional Internal CD ROM Kit including:*
  - 1) *2-Slots Bus card (ISA bus \*1, PCI/ISA bus \* 1)*
  - 2) *Internal CD ROM with Cable*
  - 3) *Metal bracket + Front Panel for Internal CD ROM*
  - 4) *Sound card*
3. **SUSPEND MODE:** *Optional for ODM*
4. **USB (Universal Serial Bus):** *Optional for ODM*
5. **PS/2 Keyboard port:** *Optional for ODM or Optionally supplies conversion adapter for DIN to MINI DIN of PS/2 keyboard. (Modifying)*

*Note : All brand names and trademarks are the property of their respective owners.*

## **CHAPTER 2    SYSTEM CONFIGURATION - GETTING FAMILIAR WITH DTV-07C**

### **2.1    The System Unit Chassis:**

The following information will help acquaint you with the arrangement of the DTV-07C computer.

When you open the box; what you will have will be same as Figure 2-1:

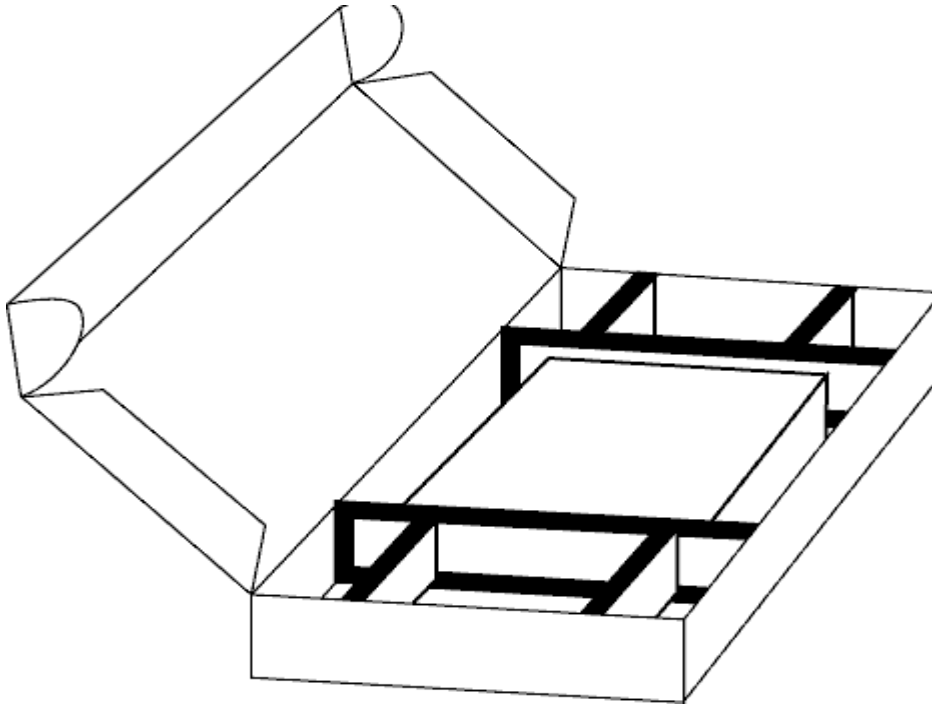

Figure 2-1 Export Packing

Figure 2-1 shows the full packing. In each set of packing, in both sides we might put : power cord, mouse (option), and in the center is the system unit containing 3.5" floppy disk , hard disk (option), internal CD ROM (option).

### **2.2    The Front Panel Composition:**

#### ***The Front Panel Composition:***

From left to right, the front panel of DTV-07C contains the following:

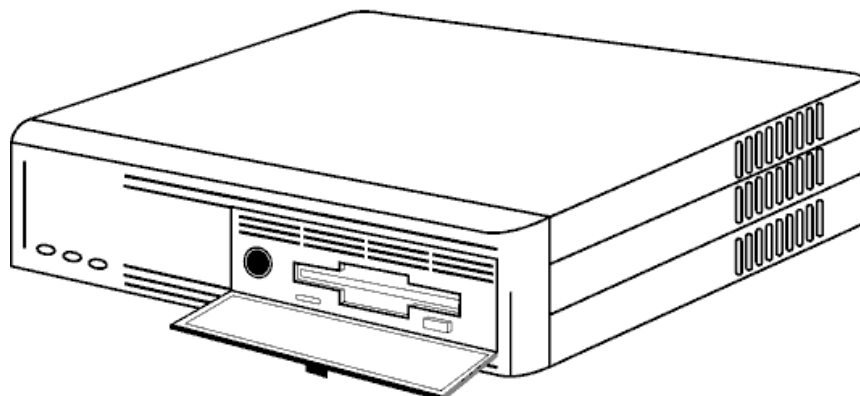

Figure 2-2 Front View of System Unit

### 2.3 The Rear Panel Composition:

From left to right, the rear panel of DTV-07C contains the following:

- ① AC Power Input    ② AC Power Output    ③ PS/2 Mouse Port
- ④ Parallel Port    ⑤ LCD Connector    ⑥ COM1 Port    ⑦ COM2 Port
- ⑧ CRT Port    ⑨ COM3 Port    ⑩ keyboard Port    ⑪ COM4 Port
- ⑫ Pulling Knob
- ⑬ Expansion slots for upgrade

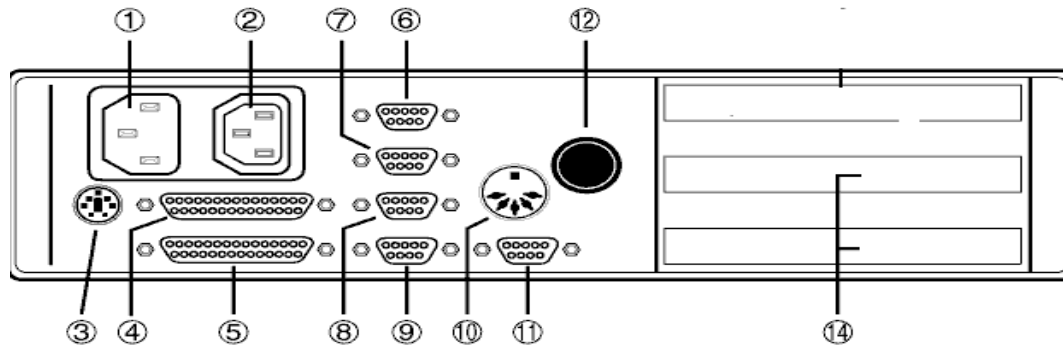

Figure 2-3 Rear View of System Unit

### 2.4 The System Internal Composition:

- ① Power Supply: AC Input 90~264V    ② HDD/FDD Holding Set    ③ Mainboard
- ④ Combo card — Ram Disk, Cash Drawer built-in,    ⑤ SLOT card
- ⑥ LED (Turbo, Power, HDD)    ⑦ AC Power Switch    ⑧ Front door

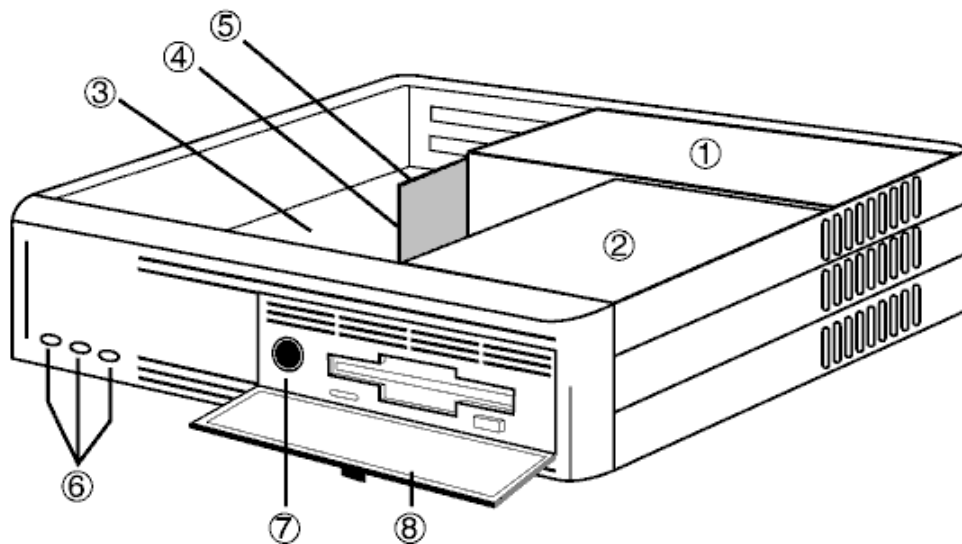
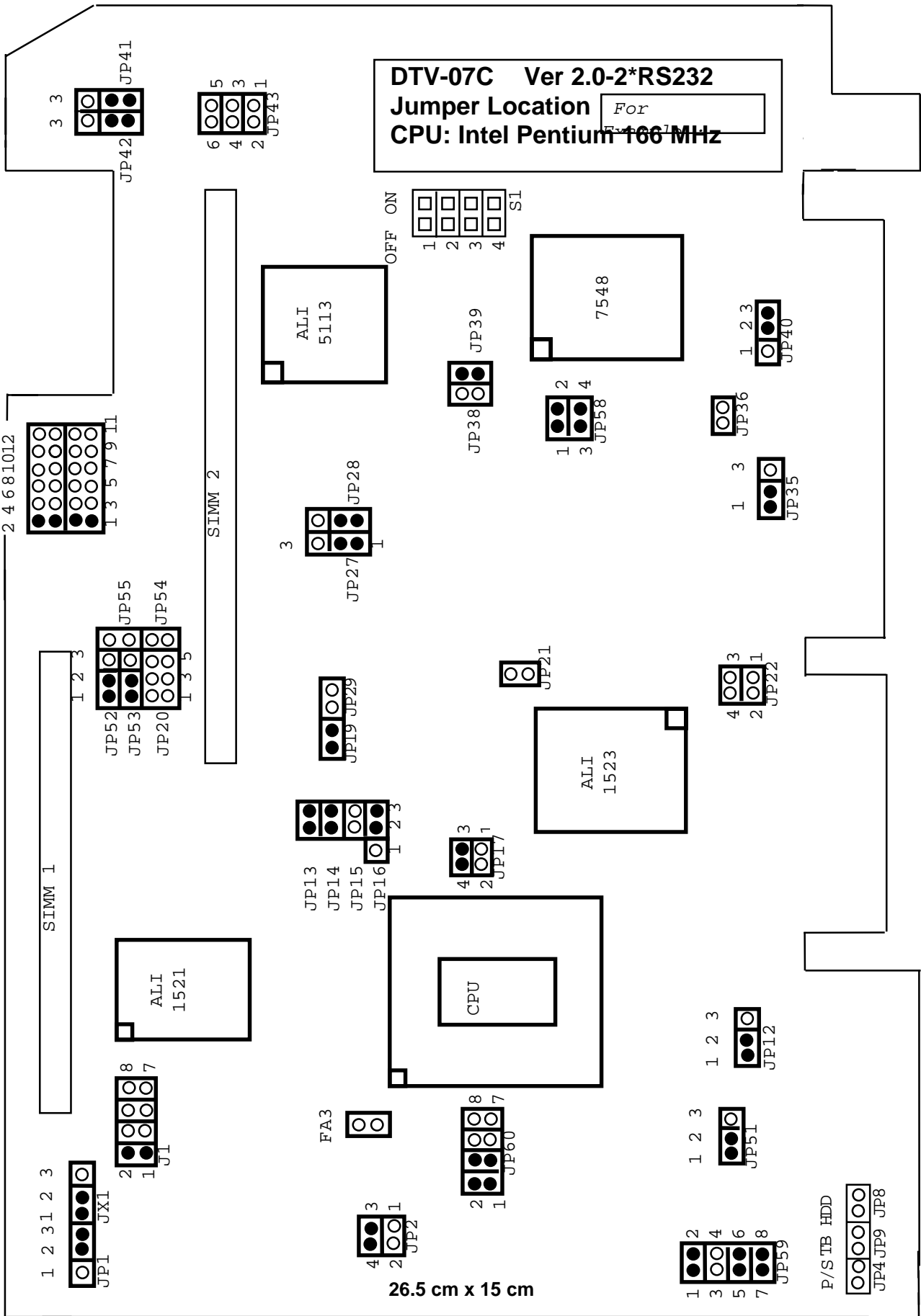
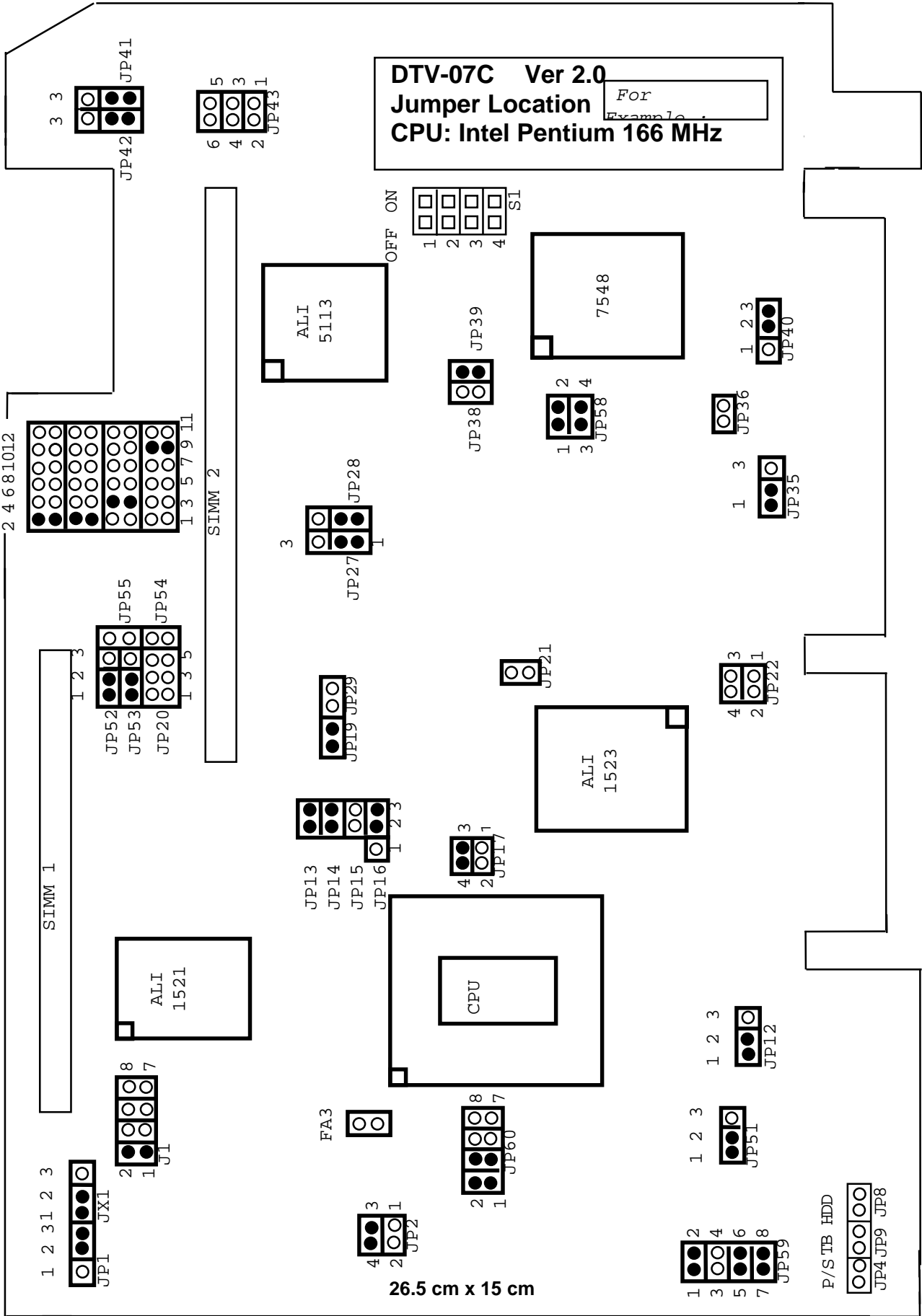

Figure 2-4 The System Internal Composition

# DTV-07C Mainboard Layout (2\* RS-232 Version)



# DTV-07C Mainboard Layout (4\* RS-232 Version)



***\* Specification of MC-7000 Pentium™ 586 AIO Logic board***

<b>CPU:</b>	Supports full series of Intel Pentium™ CPU, Cyrix/IBM, AMD
<b>CPU CLOCK -</b>	Intel Pentium™ 75Mhz up to 200Mhz , Cyrix (IBM)
<b>CPU VOLTAGE -</b>	6x86 ..166+(W/Zero Force Microprocessor Socket) 5V, onboard voltage regulator: 2.5V/ 3.3V/ 3.45V/ 3.56V
<b>MAIN MEMORY:</b>	<b>72 Pin SIMM x 4 +168 Pin DIMM x 1 (64 MB RAM capacity)</b>
<b>BIOS</b>	<b>AMI BIOS (Flash ROM )</b>
<b>SYSTEM Chip set</b>	<b>ALI 1521, 1523, 5113 Chip set</b>
	<i>system BIOS complying with PLUG and PLAY</i>
<b>CACHE MEMORY:</b>	<b>256KB P.B.S RAM onboard</b>
<b>EXPANSION BUS:</b>	<i>Support Free 7-Slots Bus Card consisting of :</i> <b>ISA bus * 4 , PCI/ ISA bus * 3.</b>
<b>SERIAL PORT</b>	2 RS-232 COM ports, freely selectable IRQ & BASE ADDRESS RANGE
<b>PRINTER PORT:</b>	<b>LPT1, 25pin Dsub connector, SPP/EPP/ECP</b>
<b>ENHANCE PCI IDE:</b>	<i>Supports devices - Primary for HDD, Secondary for CD ROM</i>
<b>FDD PORT:</b>	<i>Supports 2 devices</i>
<b>KEYBOARD PORT:</b>	<b>Standard AT DIN keyboard.</b>
<b>BUZZER:</b>	Yes
<b>BACKUP BATTERY:</b>	DALLAS or DALLAS compatible
<b>POWER INPUT:</b>	+5V,-5V,+12V, -12V.
<b>PCB SIZE:</b>	330 x 220 mm
<b>OPERATION / STORAGE TEMPERATURE:</b>	0 °C to 55 °C / -25 °C to 70 °C
<p>Jumper Block :</p> <ul style="list-style-type: none"> <li>a. IRQ-6 line</li> <li>b. DMA-2 line</li> <li>c. System Clock line</li> <li>d. Time of day clock line</li> <li>e. All IRQ lines</li> <li>f. FDD Read line</li> <li>g. FDD Write line</li> <li>h. HDD Read line</li> <li>I. HDD Write line</li> <li>j. KBD Date line</li> <li>l. Pentium R/W Iline</li> <li>m. CMOS-to-battery voltage line</li> </ul>	

**REMARK:**

1. Fully socketed mother board using piggy-back method for all ASICs.  
(ALI 1521 \* 1, 1523 \* 1, 5113 \* 1 catch ram \* 2)
2. Fully socketed for all TTL ICS.
3. Min. Order: 250 PCS



**\* IRQ & I/O MAP of DTV-07C Pentium™ 586 AIO Logic board**

<i>Logic Board</i>	<i>IRQ (Factory Default)</i>	<i>I/O map (Factory Default)</i>	<i>Mem Map (Factory Default)</i>	<i>Remark</i>
SYSTEM TIMER	0	040-05F		
KEYBOARD	1	060-06F		
PS/2 MOUSE PORT	12			
COM 1	4	3F8		Hardware/Software selectable IRQ 3,4,5,7,9,10,11.
COM 2	3	2F8		ditto
*** COM 3 (4S Ver.)	5	3E8		ditto
*** COM 4 (4S Ver.)	9	2E8		ditto
LPT	7	378		
PCI IDE PRIMARY	14	1F0		
PCI IDE SECONDARY	15	017		
FLOPPY DISK	6	3F0		
PCI VGA			C000- C7FF	
***WATCHDOG (4S Ver.)	NA	200-201		Jumper Selectable , 280-281 300-301, 380-381
PCI LAN CARD	11	300		Optional item

**Remarks :**

**System Board Chipset : ALI 1521/1523**  
**Super I/O Chipset : ALI M5113 & 16C2550**  
**PCI LCD/VGA chip : Cirrus Logic 7548**  
**Watchdog Timer: DTV ODM**  
**PCI LAN card: Optional Item.**

## **2.5 The Connector & Jumper Pin Location:**

**Following pages are tables of DTV-07C Jumper Setting for:**

- ✓ CPU TYPE
- ✓ CPU VOLTAGE REGULATOR OUTPUT
- ✓ CACHE RAM SIZE
- ✓ CMOS
- ✓ SYSTEM BIOS FLASH ROM VOLTAGE
- ✓ ENHANCED SUPER I/O
- ✓ VGA
- ✓ WATCHDOG
- ✓ POWER MANAGEMENT FOR LCD PANEL
- ✓ CPU COOLING FAN

*Note: In following pages, the jumper setting with “\*” mark means Factory default value on regular shipments.*

# DTV-07C JUMPER SETTING

“\*” remarks “factory default”

## CPU TYPE

					JP13	JP14	JP15	JP17		JX1
					CORE/BUS RATIO		CPU	(BUS) Freq.		CPU
CPU Model	Freq.	(BUS) Freq.	Voltage	RATIO			Type	1, 2	3, 4	Type
AMD-SSA/5-75ABR	75MHz	50MHz	3.52V	1.5x	Open	Open	Open	Short	Short	1, 2
AMD-K5-PR90ABQ	90MHz	60MHz	3.52V	1.5x	Open	Open	Open	Short	Open	1, 2
AMD-K5-PR100ABR	100MHz	50MHz	3.52V	2x	Open	Short	Open	Short	Short	1, 2
AMD-K5-PR133ABQ	133MHz	66MHz	3.52V	2x	Open	Short	Open	Open	Short	1, 2
AMD-K5-PR166ABR	166MHz	66MHz	3.52V	3x	Short	Short	Open	Open	Short	1, 2
IBM26 6x86-2V2100GB	100MHz	50MHz	3.3V	2x	Short	Short	Short	Short	Short	2, 3
6x86-P150+	120MHz	60MHz	3.52V	2x	Open	Short	Short	Short	Open	2, 3
6x86L-P150+ (1)	120MHz	60MHz	2.8/3.3	2x	Open	Short	Short	Short	Open	2, 3
6x86-P166+	133MHz	66MHz	3.52V	2x	Open	Short	Short	Open	Short	2, 3
Intel Pentium	100MHz	50MHz	3.3V	2x	Open	Short	Open	Short	Short	1, 2
Intel Pentium	120MHz	60MHz	3.3V	2x	Open	Short	Open	Short	Open	1, 2
Intel Pentium	133MHz	66MHz	3.3V	2x	Open	Short	Open	Open	Short	1, 2
Intel Pentium	166MHz	66MHz	3.3V	2.5x	Short	Short	Open	Open	Short	1, 2
Intel Pentium	200MHz	66MHz	3.3V	3x	Short	Open	Open	Open	Short	1, 2

(1) Dual Supply (split rail) devices

**NOTE: Specific Cooling Heat Sink is requested and supported by DTV wherever any of the CPU Type is chosen from the SHADING areas in the CPU TYPE TABLE above.**

### JP59 CPU VCORE Voltage Selector

VOUT	1 - 2	3 - 4	5 - 6	7 - 8	
2.2V	OPEN	SHORT	OPEN	OPEN	
2.6V	OPEN	SHORT	SHORT	OPEN	
2.7V	SHORT	SHORT	SHORT	OPEN	
2.8V	OPEN	OPEN	OPEN	SHORT	
2.9V	SHORT	OPEN	OPEN	SHORT	
3.2V	OPEN	OPEN	SHORT	SHORT	
3.3V	SHORT	OPEN	SHORT	SHORT	* default
3.5V	SHORT	SHORT	SHORT	SHORT	

### JP60 CPU 3V Selector

	1 - 2	3 - 4	5 - 6	7 - 8	
Single Power	SHORT	SHORT	OPEN	OPEN	*default
Dual Power	OPEN	OPEN	SHORT	SHORT	

### CMOS Clear

	Normal *	Clear CMOS
JP21	Open	Short

If you forget password, you must clear CMOS RAM and reconfigure the system.

### SYSTEM BIOS Flash ROM Voltage Selector

	FLASH ROM +12V *	FLASH ROM + 5V
JP35	1, 2	2, 3

### CACHE RAM SIZE

	256 KB	512 KB
JP1	2, 3 *	1, 2

# Enhanced Super I/O

## M5113 Enhanced Super I/O Controller

M5113	Enabled *	Disabled
JP12	1, 2	2, 3

## COM1, 2, 3, 4, IRQ Selector

		IRQ3	IRQ4	IRQ5	IRQ7	IRQ9	IRQ10	IRQ11
COM1	JP23		1, 2 *	3, 4	5, 6	7, 8	9, 10	11, 12
COM2	JP24	1, 2 *		3, 4	5, 6	7, 8	9, 10	11, 12
COM3	JP25		1, 2	3, 4 *	5, 6	7, 8	9, 10	11, 12
COM4	JP26	1, 2		3, 4	5, 6	7, 8	9, 10 *	11, 12

## COM3, COM4 Address Selector

	COM3(3F8) / COM4(2F8)	COM3(3E8) / COM4(2E8) *
JP29	Short	Open

## COM1 ~ COM4 D-SUB9 Pin Normal OR Add +5V For CCD

		Normal *	Add +5V for CCD
COM1	JP42	1, 2	2, 3
COM2	JP41	1, 2	2, 3
COM3	JP27	1, 2	2, 3
COM4	JP28	1, 2	2, 3

## COM3, COM4 RS232 / RS422 / RS485 Type Selector

Serial Port	JP20	RS-232	RS-422	RS-485	
				Model 1	Model 2
COM3	1, 2	Open *	Short		
COM4	3, 4	Open *	Short	Open	Short
Map to JP43	5, 6	Open *	Open	Short	Short

## COM4 Selector

	RS-232/ * RS-422	RS-422 by Terminator	RS-485	RS-485 by Terminator
1, 2	Open	Open	Short	Short
3, 4	Open	Open	Short	Short
5, 6	Open	Short	Open	Short

## COM3 Selector

	Type Selector	
	RS-232 * RS-422	RS-422
JP52	1, 2	2, 3
JP53	1, 2	2, 3

## COM3, COM4 Enabled or Disabled Selector

Serial Port	Enabled *	Disabled
COM3 JP54	Open	Short
COM4 JP55	Open	Short

# VGA

## On Board VGA Selector

	Enabled *	DISABLE
JP58	1,2 Short 3,4 Short	1,2 Open 3,4 Open
JP40	2,3 Short	1,2 Short

## Use VGA Bank 1 (U43, U44 256K\*16 DRAM)

	Enabled *	Disabled
JP36	Open	Short

## VGA Selector use IRQ2/9

	None use IRQ2/9 *	Use IRQ2/9
JP38	Open	Short

## VGA Selector MCLK or XMCLK

	MCLK	XMCLK
JP39	Short *	Open

## LCD Panel Screen Setting

Code for Panel Supported	Panel Description	Panel Resolution	S1		
			1	2	3
	TFT	640*480	Off	Off	On
	TFT	800*600	Off	Off	Off
	DSTN	640*480	On	Off	On

**DTV-07C RS422/485 Interface Connection Table**

**Onboard: JP47,48**  
**2\*5 Jumper Pin**

				RS422 Output DB9-Sub Male		RS485 Output DB9-Sub Male	
GND	1	•	•	2	CTS+	1	GND
RTS+	3	•	•	4	CTS-	2	RTS+ (N.U)
RTS-	5	•	•	6	RXD+	3	RTS- (N.U)
						4	TXD+ S.C.
TXD+	7	•	•	8	RXD-	8	RXD+
TXD-	9	•	•	10	N.C	6	CTS+ (N.U)
						7	CTS- (N.U)
						8	RXD+ S.C
						9	RXD-

\* S.C.: Short Circuit

**\*\* COM3 RS422:JP47, COM4 RS422: JP48 or COM4 RS485: JP48**

**DTV-07C RS232 Interface Connection Table**

**Onboard: J7,8, JP45,46**  
**2\*5 Jumper Pin**

				RS232 Output DB9-Sub Male		RS232/422/485 use the same Cable	
DCD	1	•	•	2	DSR	2*5 IDC	D-SUB9P Male
RXD	3	•	•	4	RTS	1	1
TXD	5	•	•	6	CTS	2	6
DTR	7	•	•	8	RI	3	2
GND	9	•	•	10	N.C	4	7
						5	3
						6	8
						7	4
						8	9
						9	5

**\*\* COM1 RS232:JP7, COM2 RS232:JP8, COM3 RS232: JP45, COM4 RS232: JP46**

## Watch Dog

### Watch Dog Selector

	Enabled	Disabled *
JP16	1, 2	2, 3

### Watch Dog Timer Selector

JP2	1, 2	3, 4 *
J1	Timer	Timer
1, 2 *	4 Seconds	60 Seconds
3, 4	8 Seconds	120 Seconds
5, 6	12 Seconds	180 Seconds
7, 8	16 Seconds	240 Seconds
	<i>For Manufactory Test</i>	<i>For factory Dispatch</i>

### Watch Dog I/O Port Address Selector

JP22	WDCLK Address	200H *	280H	300H	380H
	RIG Address	201H	281H	301H	381H
1, 2		Open	Open	Short	Short
3, 4		Open	Short	Open	Short

### Power Management Selector For LCD Panel

	Suspend Mode		Standby Mode	
	Enabled	Disabled	Enabled	Disabled
JP33	Open *	Short		
JP34			Open *	Short

Map to JP31 (Manufactory Setup)  
Map to JP32 (Manufactory Setup)

### CPU Cooling FAN(FA3) use +5V or +12V Selector

JP51	Voltage
1,2	+12V *
2,3	+ 5V

JP3 Buzzer

JP4 POWER LED

JP8 Turbo LED

JP9 HDD LED

FAN, FA1 FAN Connector

KB1 Keyboard Connector (5 Pin Female)

J10 VIDEO Connector (15 Pin Female)

J2 Floppy Driver Connector

J3 Primary IDE Connector

J9 LCD Panel Connector (44 Pin Female)

JP50 PS/2 Mouse Connector (6 Pin Female)

J8 COM1

J7 COM2

JP45 COM3

JP46 COM4

JP47 RS-422 FOR COM3

JP48 RS-422/RS-485 FOR COM4

## CHAPTER 3 UPGRADING

### NOTE:

Your warranty remains in effect only if an authorized dealer or technician adjusts the internal settings. This section is intended only for those users who wish to perform the adjustments themselves and void the warranty.

At any time, you can add (or remove) hardware to your DTV-07C computer and modify its capabilities. The information in this chapter will instruct you on how to open the chassis.

### 3.1 Removing The Cover:

WARNING : make sure that the power to your systems, as well as any peripheral devices, is off before removing the chassis.

Remove 2 screws located at the both sides of the system. Use the pulling knob to pull out the system tray from the chassis. The system tray contains the Main Board, hard disk, floppy disk and add-on card (option)

When you remove the system from the chassis, You are suggested to mark or label plugs for correct orientation for simplified reassemble. Improperly plugging connectors or plugs can damage your system when you power it up.

Ready with a tray to hold screws, and label the tray so you know where the screws will go for reassemble. Since your system required different sizes of screws, keeping screws separated will save you time and minimize frustration.

#### 3.1.1 Tools

You will need a few simple tools to remove the DTV-07C Compact Line PC Machine.

- \* Philips screwdriver
- \* Labeling material (tape, paper, pen) (optional)
- \* Cups or trays to hold various screws (optional)

#### 3.1.2 Adding Add-On Card:

DTV-07C includes 3 slots card for additional peripheral.

WARNING : Because of DTV-07C space-saving design, it is restricted that the additional Add-on card for DTV-07C is within the **maximum dimension: 108 mm (height) \* 250mm (length)**. Please make sure that the Add-on card you are going to plug in DTV-07C systems is according to this requirement.

### 3.2 Installing The Hard Disk:

WARNING: If you buy a DTV-07 without hard disk and you like to upgrade it later. Please consult with your dealer. The procedures are as following:

1. Apply 3.1 opening the DTV-07C case.
2. Pull pulling knob to remove the outside case.
3. Screw on the hard disk and connect power cable and data cable. Select right power cable for different brand Hard Disk.
4. Test the system and format hard disk before screwing in the system CHASSIS. Make sure the system is in good condition.
5. By opposite direction to screw on the systems.



### 3.3 Memory Configuration:

The DTV-07C lets you increase the system main memory via onboard SIMM (Single in-Line Memory Modules) Sockets. The DTV-07C supports Two banks of 4/8/12/16/20/24/32...MB SIMM Modules. The DTV-07C requires SIMM:

3.3.1 Suggested to use EDO SIMM Memory Modules

3.3.2 For FP SIMM Memory Modules, it is suggested to use 60ns.

3.3.3 It is able to use FP or EDO only with the same type of Memory Modules at the same time.

The DTV-07C support the following configuration:

Memory Size	BANK 0 (SIMM 1)	BANK 1 (SIMM 2)
4MB	1*4MB	N.C.
8MB	1*4MB	1*4MB
	1*8MB	N.C.
12MB	1*8MB	1*4MB
16MB	1*8MB	1*8MB
	1*16MB	N.C.
20MB	1*16MB	1*4MB
24MB	1*16MB	1*8MB
32MB	1*16MB	1*16MB
	1*32MB	N.C.
64MB	1*32MB	1*32MB

## CHAPTER 4 BIOS SETUP

### 4.1 Setup Overview:

The DTV-07C contains its own permanently programmed SETUP routing, which allows it to recognize and utilize the system's hardware, for example, one can set the system to identify hard disk and floppy disk drive capacity, the type of video being used, and the amount of memory installed. The BIOS (BASIC input / output System) will read this information each time the system boots up. In the first time the system is powered on, please run SETUP to configure it properly.

### 4.2 AMI BIOS Setup:

The BIOS setup program provided with the Main Board is the AMI BIOS from American Megatrends Inc.. Enter the AMI Setup program's Main Menu as following:

1. Turn on or reboot the system.
2. After a serial of diagnostic check; press the <DEL> key to enter the AMI BIOS setup program and the following screen appears :
- \*3. *Pls selector the "Auto Configuration with Optimal Settings" First.*

### DTV-07C Compact Line System BIOS Setup Manual

#### 4.2.1. SETUP:

##### A. Standard:

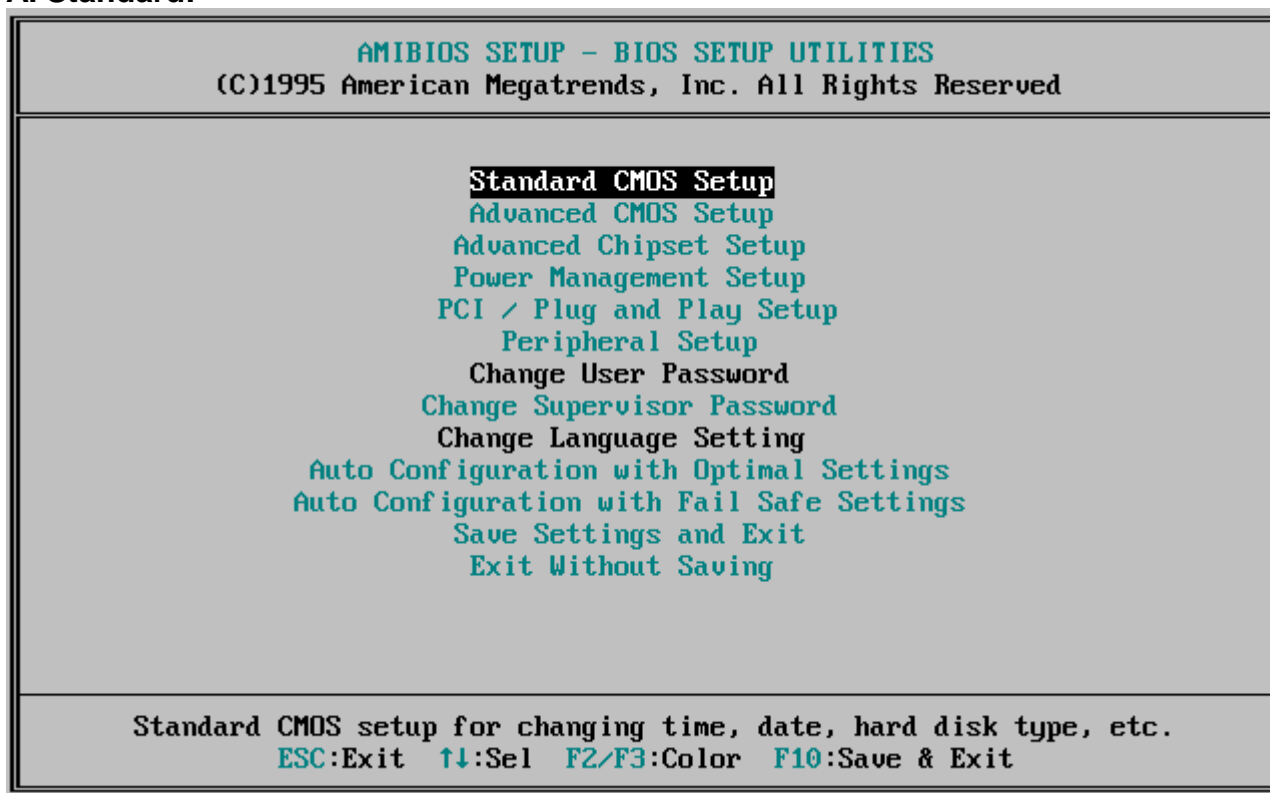

**AMIBIOS SETUP - STANDARD CMOS SETUP**  
 (C)1995 American Megatrends, Inc. All Rights Reserved

Date (mm/dd/yyyy): Fri **Feb** 21, 1997  
 Time (hh/mm/ss): 15:21:48

Floppy Drive A: 1.44 MB 3½  
 Floppy Drive B: Not Installed

	Type	Size	Cyln	Head	WPcom	Sec	LBA Mode	Blk Mode	PIO Mode	32Bit Mode
Pri Master	: Auto						On	On	Auto	Off
Pri Slave	: Auto						On	On	Auto	Off
Sec Master	: Auto						On	On	Auto	Off
Sec Slave	: Auto						On	On	Auto	Off

Boot Sector Virus Protection Disabled

Month: Jan - Dec  
 Day: 01 - 31  
 Year: 1901 - 2099

ESC:Exit ↑:Sel  
 PgUp/PgDn:Modify  
 F2/F3:Color

**AMIBIOS SETUP - ADVANCED CMOS SETUP**  
 (C)1995 American Megatrends, Inc. All Rights Reserved

<b>Quick Boot</b>	<b>Disabled</b>
BootUp Sequence	A:,C:
Memory Test Tick Sound	Enabled
BootUp Num-Lock	On
Floppy Drive Swap	Disabled
Mouse Support	Enabled
System Keyboard	Present
Primary Display	UGA/EGA
Password Check	Setup
Parity Check	Disabled
OS/2 Compatible Mode	Disabled
CPU MicroCode Updation	Disabled
Internal Cache	WriteBack
External Cache	WriteBack
System BIOS Cacheable	Enabled
Video BIOS Shadow	Cached
C800,16k Shadow	Disabled
CC00,16k Shadow	Disabled
D000,16k Shadow	Disabled
D400,16k Shadow	Disabled

Available Options:  
 Disabled  
 Enabled

ESC:Exit ↑:Sel  
 PgUp/PgDn:Modify  
 F2/F3:Color

**AMIBIOS SETUP - ADVANCED CHIPSET SETUP**  
 (C)1995 American Megatrends, Inc. All Rights Reserved

<b>Async. SRAM Write WS</b>	<b>X-2-2-2</b>
Async.SRAM Read WS	X-2-2-2
Read Speculative	Disabled
EDO Read WS	X-2-2-2
Page Mode Read WS	X-3-3-3
DRAM Write WS	X-3-3-3
SDRAM Access Timing	Fastest
SDRAM CAS Latency	3
Slow Refresh	60 us
Pipelined Function	Enabled
DRAM Data Integrity Mode	Parity
Primary Frame Buffer	2 MB
UGA Frame Buffer	Enabled
Data Merge	Enabled
Byte Merge	Disabled
Passive Release	Enabled
ISA Line Buffer	Enabled
Delay Transaction	Enabled
AT Bus Clock	Auto

**Available Options:**  
 X-3-3-3  
 X-2-2-2

ESC:Exit   ↑↓:Sel  
 PgUp/PgDn:Modify  
 F2/F3:Color

**AMIBIOS SETUP - POWER MANAGEMENT SETUP**  
 (C)1995 American Megatrends, Inc. All Rights Reserved

<b>Power Management/APM</b>	<b>Disabled</b>
Power Down HDD In	Disabled
Power Down UGA In	Disabled
UGA Power Down Mode Select	Normal
Doze Time Out	Disabled
Standby Time Out	Disabled
Suspend Time Out	Disabled
Monitor UGA	No
Monitor DRQs	No
Monitor IRQs	No
IRQ3 (COM2)	Ignore
IRQ4 (COM1)	Ignore
IRQ5 (LPT2)	Ignore
IRQ6 (Floppy Disk)	Ignore
IRQ7 (LPT1)	Ignore
IRQ9 (Redirect)	Ignore
IRQ10 (Reserved)	Ignore
IRQ11 (Reserved)	Ignore
IRQ12 (PS/2 Mouse)	Ignore
IRQ14 (Hard Disk)	Ignore

**Available Options:**  
 Disabled  
 Enabled

ESC:Exit   ↑↓:Sel  
 PgUp/PgDn:Modify  
 F2/F3:Color

**AMIBIOS SETUP - PCI / PLUG AND PLAY SETUP**  
 (C)1995 American Megatrends, Inc. All Rights Reserved

<b>Plug and Play Aware O/S</b>	<b>Yes</b>
PCI VGA Palette Snoop	Disabled
PCI IDE BusMaster	Disabled
OffBoard PCI IDE Card	Auto
OffBoard PCI IDE Primary IRQ	Disabled
OffBoard PCI IDE Secondary IRQ	Disabled
Used ESCD IRQ Info.	No
IRQ3	ISA/EISA
IRQ4	ISA/EISA
IRQ5	ISA/EISA
IRQ7	ISA/EISA
IRQ9	ISA/EISA
IRQ10	PCI/PnP
IRQ11	PCI/PnP
IRQ14	PCI/PnP
IRQ15	PCI/PnP
Reserved Memory Size	Disabled
Reserved Memory Address	C8000

Available Options:  
 No  
 Yes

ESC:Exit   ↑↓:Sel  
 PgUp/PgDn:Modify  
 F2/F3:Color

**AMIBIOS SETUP - PERIPHERAL SETUP**  
 (C)1995 American Megatrends, Inc. All Rights Reserved

OnBoard FDC	Enabled
OnBoard Serial Port1	3F8h
Serial Port1 Mode	Normal
Serial Port1 Duplex	Half
RXD1/TXD1 Polarity	Hi/Hi
OnBoard Serial Port2	2F8h
Serial Port2 Mode	Normal
Serial Port2 Duplex	Half
RXD2/TXD2 Polarity	Hi/Hi
IR Pin Used By	RXD2/TXD2
OnBoard Parallel Port	378h
Parallel Port IRQ	7
Parallel Port Mode	Normal
EPP Mode	1.9
Parallel Port DMA Channel	3
OnBoard Primary IDE	Enabled
<b>OnBoard Secondary IDE</b>	<b>Enabled</b>

Available Options:  
 Disabled  
 Enabled

ESC:Exit   ↑↓:Sel  
 PgUp/PgDn:Modify  
 F2/F3:Color

## **CHAPTER 5     DTV-07C VGA chip - Cirrus Logic GD-7548 DISPLAY INTERFACE CONNECTION**

### **NOTE:**

DTV-07C built with *VGA chip - Cirrus Logic GD-7548* features display output to connect either CRT or LCD Panel separately, also able to connect both CRT and LCD Panel simultaneously. You need to carefully peruse this part to realize how to get the connection properly and correctly.

### **5.1     WARNING:**

5.1.1. It is a must to have either CRT or LCD Panel connected with DTV-07C before system booting; as the *VGA chip - Cirrus Logic GD-7548* design is first to check CRT VGA output then to check LCD Panel VGA output. In case you do not have either CRT or LCD Panel connected, after detecting LCD Panel; PC will get the signal and disable display function. Hence you will not have the display if you connect Display after system power-on.

5.1.2. In case you want to connect both displays of CRT and LCD Panel simultaneously, you need to firstly run the specific software utility of *Cirrus Logic GD-7548*.

5.1.3. Be sure which type of LCD Panel you will use such as DSTN or TFT and the correct resolution. Make sure to set the exact switch in the location "S1" switch to match your LCD Panel type. (Refer to the table of "5.3")

### **5.2     DTV-07C VGA chip - Cirrus Logic GD-7548 features as following:**

- 32bit Cirrus Logic 7548 chip default 1MB, up to 2MB
- Display output to connect either MONITOR or COLOR LCD
- Connectors: CRT 15pin DSub and LCD 44pin DSub.
- Integrated programmable frequency synthesizer, 24bit true-color RAMDAC, 64\*64 pixel size hardware pop-up icons.
- LCDs: 640\*480 (VGA), 800\*600 (SVGA) and 1024\*768 (XGA)

**5.3 DTV-07C VGA chip - Cirrus Logic GD-7548 location "S1" Switch setting for LCD Panel Class:**

**Location "S1" Switch Setting for Selecting the LCD Panel Class**

Table	PANEL DESCRIPTIONS	Code for Panel Supported	Panel Screen Format	Mark's LCD Product Model No.	switch position setting		
					1	2	3
0	Color Single-scan active-matrix TFT 18bit, 12bit, or 9bit	C256KSS-18 **** ****(default) C4KSS-12 C512SS-9	640*480 TFT	RTC-5200 10.4" TFT	On	On	On
1	Color Single-scan active-matrix TFT 18bit, 12bit, or 9bit	C256KSS-18 **** ****(default) C4KSS-12 C512SS-9	640*480 TFT	REX ODM 10.4" TFT	Off	On	On
2	Color Dual-scan passive STN 16bit	C8DD-16	640*480 DSTN	RTC-4000 RTC-4100 ST-020A	On	Off	On
3	Color Single-scan active-matrix TFT 18bit, 12bit, or 9bit	C256KSS-18 **** ****(default) C4KSS-12 C512SS-9	640*480	<i>DTV</i>  <i>Data-Touch</i> <i>10.4" TFT</i> <i>LCD Panel</i>	Off	Off	On
4	Color Dual-scan passive STN 16bit Example: Sharp LM64C15P and Sharp LM6435P	C8DD-16	640*480		Off	On	Off
5	Monochrome Dual-scan passive STN 8-BIT	M2DD-8	640*480 MONO	RTC-3000	On	On	Off
6	Color Single-scan active-matrix TFT, 18bit, 12bit, or 9bit	C256KSS-18 **** C4KSS-12 C512SS-9	640*480 TFT	ST-010A	On	Off	Off
7	Color Single-scan active-matrix TFT 18bit, 12bit, or 9bit	C256KSS-18 **** ****(default) C4KSS-12 C512SS-9	800*600 TFT	<i>DTV</i>  <i>Data-Touch</i> <i>12.1" TFT</i> ST-011A	Off	Off	Off

*Note : All brand names and trademarks are the property of their respective owners.*

**Update Note: M/B VER.: 4.0    BIOS VER.: L2    DATE: APRIL 23, 1999**

**5.4 DTV-07C LCD 44pin Connector Output PIN to Cirrus Logic GD-7548 PIN interface connection Table:**

<b>DTV-07C LCD 44 Pin Connector Output Pin (J9)</b>	<b>MINI DIP 22 X 2</b>	<b>Cirrus Logic GD-7548 Pin</b>	<b>Pin Defines</b>
1	6	105	FPBL
2	5	134	FP17
3	9	118	FP4
4	11	133	FP16
5	4	128	FP12
6	3	125	FP9
7	1	137	FP20
8	2	123	FP8
9	44	119	FP5
10	43	115	FP1
11	42	129	FP13
12	41	114	FP0
13	39	138	FP21
14	40	140	FP23
15	37	108	FPDE
16	16		NC
17	7		+12V
18	10	116	FP2
19	12	120	FP6
20	13	126	FP10
21	15	130	FP14
22	20	135	FP18
23	22	139	FP22
24	26	117	FP3
25	25	122	FP7
26	28	127	FP11
27	32	131	FP15
28	35	136	FP19
29	34	113	FPVDCLK
30	38	110	LFS
31	8		+12V
32	23		NC
33	17		GND
34	14	102	FPVEE
35	18		GND
36	19		GND
37	27		NC
38	24	106	FPVCC
39	29		Vcc
40	21		GND
41	30		Vcc
42	33		NC
43	31		Vcc
44	36		LLCLK



**5.5 The Recommended LCD makerlist for DTV-07C from which Factory(DTV) has evaluated and approved on 100% compatibility while working with DTV-07C.**

LCD usage is more and more popular in PC standard platform. For perfect compatibility; DTV recommends the LCD Displays from the makers as listed below and the specific cables. Buyers are free to separately purchase DTV-07C from DTV and purchase LCD Displays from these LCD makers with a necessary quotation of “Applicable CABLE CODE for DTV DTV-07C ” (refer to the table below) on the purchase order form:

<b>Maker</b>	<b>LCD type</b>	<b>LCD resolution</b>	<b>LCD internal model number</b>	<b>Maker's LCD Product number</b>	<b>Cable Code</b>
<b>RTC</b>	TFT Color	640*480	LT104V3-101 Sumsung	RTC-5200	9004
	DSTN TYPE 2	640*480	LM9723 Hitachi	RTC-4000	DR01
<b>SOTAC (SUN-UP)</b>	TFT Color	800*600	113BLM-1 NEC	ST-011A	TS01
	TFT Color	640*480		ST-010A	TS01
	DSTN Color	640*480	LM-CG53-22NTK Sanyo	ST-020A	DS01

\*\* Contact information of above LCD makers are available on request.

**The Interface Connection Table between Recommended LCD makerlist for DTV-07C and DTV-07C Compact Line system machine:**

**5.5.1**

<b>Maker</b>	<b>LCD type</b>	<b>LCD resolution</b>	<b>LCD internal model number</b>	<b>Maker's LCD Product number</b>	<b>Cable Code</b>
<b>RTC</b>	TFT Color	640*480	LT104V3-101	RTC-5200	9004

## **The Interface Connection Table**

<b>LCD Panel Input 25 Pin (Male)</b>	<b>D-Sub (Male) 44 Pin Output</b>	<b>Pin Defines</b>
1	17, 31	+12V
2	39, 41, 43	+ 5V
3	28	R1
4	14	R5
5	5	G2
6	30	FLM
7	7	R2
8	26	G1
9	27	G5
10	3	B2
11	21	G4
12	9	B3
13	15	DE
14	34	FPVEE
15	44	LLCLK
16	13	R3
17	20	G0
18	29	FPVDCLK
19	22	R0
20	23	R4
21	11	G3
22	18	B0
23	19	B4
24	24	B1
25	25	B5

### 5.5.2

<b>Maker</b>	<b>LCD type</b>	<b>LCD resolution</b>	<b>LCD internal model number</b>	<b>Maker's LCD Product number</b>	<b>Cable Code</b>
<b>RTC</b>	<i>DSTN TYPE 2</i>	<i>640*480</i>	<i>LM9723 Hitachi</i>	<i>RTC-4000</i>	<i>DR01</i>

### **The Interface Connection Table**

<b>RTC4000 Panel 25Pin (Male)</b>	<b>D-SUB (Male) 44 Pin Output</b>	<b>Pin</b>	<b>GL-GD7548 Defines</b>	<b>Pin</b>
1	17			+12V
2	27	131		FP7
3	11	129		FP5
4	28	136		FP8
5	26	127		FP10
6	25	122		FP3
7	9	119		FP1
8	14	140		FP12
9	13	138		FP14
10	1			-FPBL
11	39			+5V
12	29			FPVDCCLK
13	30			LFS
14	31			+12V
15	21	130		FP6
16	5	128		FP4
17	22	135		FP9
18	20	126		FP11
19	19	120		FP2
20	3	118		FP0
21	23	139		FP13
22	7	137		FP15
23	35,36			GND
24	34			FPVEE
25	44			LLCLK

### 5.5.3

<b>Maker</b>	<b>LCD type</b>	<b>LCD resolution</b>	<b>LCD internal model number</b>	<b>Maker's LCD Product number</b>	<b>Cable Code</b>
<b>SOTAC</b> <b>(SUN-UP)</b>	TFT Color	800*600	113BLM-1 NEC	ST-011A	TS01
	TFT Color	640*480		ST-010A	TS01

### **The Interface Connection Table**

<b>LCD Panel Input Pin (Male)</b>	<b>D-SUB (Male) 44 Pin Output</b>	<b>Pin</b>	<b>GL-GD7548 Pin Defines</b>
1	11	129	FP5
2	21	130	FP6
3	3	118	FP0
4	9	119	FP1
5	19	120	FP2
6	25	122	FP3
7	4	133	FP17
8	10	115	FP22
9	20	126	FP11
10	15	108	FPDE
11	30	110	LFS
12	38	106	FPVCC
13	16		NC
14	12	114	FP23
15	6	125	FP18
16	5	128	FP4
17	18	116	FP21
18	24	117	FP20
19	22	135	FP9

<b>LCD Panel Input Pin (Male)</b>	<b>D-SUB (Male) 44 Pin Output</b>	<b>Pin</b>	<b>GL-GD7548 Pin Defines</b>
20	28	136	FP8
21	7	137	FP15
22	13	138	FP14
23	23	139	FP13
24	44		LLCLK
25	29	113	FPVDCLK
26	37		NC
27	34	102	FPVEE
28	1	105	FPBL
29	42		NC
30	33		GND
31	26	127	FP10
32	8	123	FP19
33	2	134	FP16
34	27	131	FP7
35	35		GND
36	36		GND
37	40		GND
38	14	140	FP12
39	32		NC
40	39		Vcc
41	41		Vcc
42	43		Vcc
43	17		+12V
44	31		+12V

### 5.5.4

<b>Maker</b>	<b>LCD type</b>	<b>LCD resolution</b>	<b>LCD internal model number</b>	<b>Maker's LCD Product number</b>	<b>Cable Code</b>
<b>SOTAC (SUN-UP)</b>	<i>DSTN Color</i>	<i>640*480</i>	<i>LM-CG53-22NTK Sanyo</i>	<i>ST-020A</i>	<i>DS01</i>

### **The Interface Connection Table**

<b>LCD Panel Input Pin (Female)</b>	<b>D-SUB (Male) 44 Pin Output</b>	<b>GL-GD7548</b>	
		<b>Pin</b>	<b>Pin Defines</b>
1	2	134	FP16
2	4	133	FP17
3	34	102	FPVEE
4	15	108	FPDE
5	30	110	LFS
6	24	117	FP20
7	13	138	FP14
8	23	139	FP13
9	14	140	FP12
10	5	128	FP4
11	11	129	FP5
12	21	130	FP6
13	27	131	FP7
14	9	119	FP1
15	19	120	FP2
16	33		GND
17	16		NC
18	1	105	FPBL
19	32		NC
20	42		NC
21	29	113	FPVDCLK
22	44		LLCLK

<b>LCD Panel</b>	<b>D-SUB (Male)</b>	<b>GL-GD7548</b>	
<b>Input Pin (Female)</b>	<b>44 Pin Output</b>	<b>Pin</b>	<b>Pin Defines</b>
23	6	125	FP18
24	8	123	FP19
25	18	116	FP21
26	10	115	FP22
27	12	114	FP23
28	20	126	FP11
29	26	127	FP10
30	25	122	FP3
31	17		+12V
32	31		+12V
33	39		Vcc
34	41		Vcc
35	43		Vcc
36	37		NC
37	38	106	FPVCC
38	35		GND
39	36		GND
40	40		GND
41	3	118	FP0
42	28	136	FP8
43	22	135	FP9
44	7	137	FP15

## **CHAPTER 6 WARRANTY POLICY**

### **LIMITED WARRANTY**

This product is warranted. To be free of defects in material and workshop. This warranty period shall begin on the invoice date and will be in effect for a period of one year for labor and one year for parts.

### **WARRANTY RETURN PROCEDURES**

The customer must call the Dealer technical support department in order to receive a return merchandise must have the following information readily available:

- 1) **Name and Address.**
- 2) **Phone Number.**
- 3) **Contact.**
- 4) **Serial Number.**
- 5) **Invoice Number.**
- 6) **Date of Purchase.**

Failure to provide complete and correct information will result in significant delays in processing your repair. Any merchandise sent to without a valid RAM will not be accepted. RMA sent C.O.D. to Dealer will not be accepted, Also Dealer will not cross-ship any repair parts, no repair will be done until the merchandise is received.

When returning merchandise for repair of refund, please mark the RMA# clearly visible on the box, otherwise this is going to delay your repair of refund. While returning for refund. You must return all parts or else you will be charged for any missing parts.

### **THE FOLLOWING SHALL VOID WARRANTY**

Any unauthorized service, modification or tampering any damages due to accident, misuse, abuse and operation outside of electrical specifications.

There will be charges for labor and/or materials on repair after the warranty period had expired.

=====

**Dealer Information:**

=====